



PRODUCT DETAILS

The Bianco NXT AUTOSUB submersible pump is specially designed and manufactured for the rainwater industry.

Being a submersible design means that the pump can be placed inside the rainwater tank for a neat, secure and quiet installation.

It is intended for use in household applications for the automatic supply of clean water which contains no fibres.

APPLICATIONS

- Household water supply
- Drinking water
- Gardening

FEATURES

- Compact
- Easy to install and use
- Automatic on/off
- Intelligent controller
- Dry-run protection
- Water-cooled motor

TECHNICAL DATA

RATED POWER (W)	750 W
MAX. FLOW [LPM]	100 L/min
MAX. FLOW [M3/H]	6 m ³ /h
MAX. HEAD [M]	45 m
MOTOR PROTECTION LEVEL	Class F
PROTECTION CLASS	IPX8
WORKING TEMPERATURE	-5° – 40°C
LIQUID TEMPERATURE	0° – 35°C
MAX. DIVING DEPTH	7 m
MAX. DIA. OF PARTICLE	1 mm
MOTOR	Heavy Copper winding

RATED VOLTAGE	220 – 240V
RATED CURRENT	5.3A @ 230V
POWER CABLE TYPE	H07RN-F
LENGTH OF POWER CABLE	10 m
PROTECTION CLASS	IPX8
IMPELLERS	4
OUTLET	1" BSPF
PACKAGE DIMENSIONS	350 x 240 x 545mm
GROSS WEIGHT (KG)	12 kg
AUTOMATION FUNCTION	iSENSOR Auto Control + Fixed Arm Float Switch
CUT-IN PRESSURE	2.5 bar

PRODUCT DATA SHEET

SUBMERSIBLE PRESSURE PUMP

BIA-AUTOSUB – 810335

CURVE

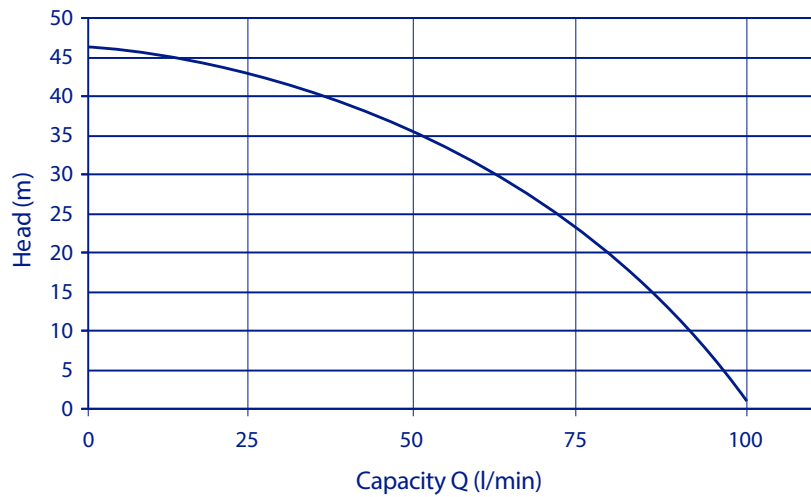

DIMENSIONS

DIMENSIONS (mm)

251 x 492

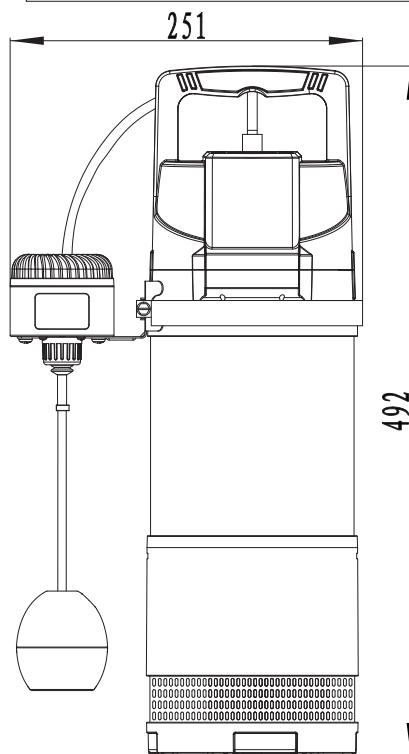

DIAMETER (mm)

159

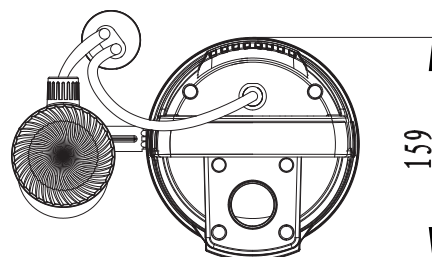

WARRANTY / CERTIFICATIONS

